

**JAM 2006**

**GEOLOGY TEST PAER**

tutoriaall.com.tutorials

**NOTE: Attempt ALL the 44 questions. Questions 1-30 (objective questions) carry three marks each and questions 31- 44 (subjective questions) carry fifteen marks each.**

**Write the answers to the objective questions in the Answer Table for Objective Questions provided on page 11 only.**

- In phyllosilicates, the tetrahedral cation to oxygen ratio is
  - 1 : 2
  - 1 : 3
  - 2 : 5
  - 4 : 11
- Which one of the following groups of organisms belongs to terrestrial / fresh-water environment?
  - Echinoids
  - Brachiopods
  - Corals
  - Pulmonate gastropods
- A hill face slopes at an angle  $40^\circ$  due east. The joint set most likely to cause landslide is the one dipping at
  - $20^\circ$  due west
  - $30^\circ$  due east
  - $60^\circ$  due east
  - $65^\circ$  due south-east
- Octahedron and Tetrahedron both have the same symbol  $\{111\}$ . The difference between the two in symmetry is
  - $\bar{3} 2/m$  and  $2/m \bar{3}$
  - $4/m \bar{3} 2/m$  and  $4 \bar{3} m$
  - $\bar{4} 2 m$  and  $4/m \bar{2} m \bar{2} m$
  - $\bar{4}$  and  $4 \bar{2} m$
- The orthopyroxene – clinopyroxene – plagioclase mineral assemblage in metabasic rocks is diagnostic of
  - granulite facies
  - amphibolite facies
  - eclogite facies
  - greenschist facies
- The optical indicatrix of garnet is
  - prolate
  - oblate
  - sphere
  - triaxial ellipsoid

7. Match the following

**Group I**

- (P) *Micraster*
- (Q) *Phacops*
- (R) *Equus*
- (S) *Barappasaurus*

**Group II**

- (1) Trilobite
- (2) Dinosaur
- (3) Mammal
- (4) Echinoid

- (A) P – 1                      Q – 2                      R – 3                      S – 4
- (B) P – 2                      Q – 1                      R – 4                      S – 3
- (C) P – 3                      Q – 4                      R – 2                      S – 1
- (D) P – 4                      Q – 1                      R – 3                      S – 2

8. In clastic sedimentary rocks, grains ranging in size from 0.0625 mm to 2.0 mm are called

- (A) granule
- (B) sand
- (C) silt
- (D) clay

9. Acme zone indicates the

- (A) range of a fossil species
- (B) absence of a fossil species
- (C) maximum abundance of a fossil species
- (D) migration of a fossil species

10. Which one of the following sedimentary features can be used to determine the unidirectional palaeocurrent?

- (A) Asymmetrical ripple marks
- (B) Symmetrical ripple marks
- (C) Parting lineation
- (D) Load cast

11. Match the following

**Group I**

- (P) plutonic rocks
- (Q) subduction zone
- (R) impact crater
- (S) volcanic rocks

**Group II**

- 1. sanidine
- 2. stishovite
- 3. microcline
- 4. jadeite

- (A) P – 2                      Q – 3                      R – 4                      S – 1
- (B) P – 3                      Q – 1                      R – 2                      S – 4
- (C) P – 4                      Q – 1                      R – 2                      S – 3
- (D) P – 3                      Q – 4                      R – 2                      S – 1

12. The feldspathoid present in phonolite is

- (A) nepheline
- (B) sanidine
- (C) kalsilite
- (D) albite

13. Match the following

**Group I**

- (P) braid bars
- (Q) moraines
- (R) barchans
- (S) atoll

**Group II**

- (1) wind
- (2) riverine
- (3) marine
- (4) glacial

- |     |       |       |       |       |
|-----|-------|-------|-------|-------|
| (A) | P – 1 | Q – 2 | R – 3 | S – 4 |
| (B) | P – 2 | Q – 4 | R – 1 | S – 3 |
| (C) | P – 4 | Q – 2 | R – 3 | S – 1 |
| (D) | P – 3 | Q – 4 | R – 1 | S – 2 |

14. The presence of pillow structures in igneous rocks is indicative of

- (A) layered basic intrusion
- (B) subaerial volcanism
- (C) submarine volcanism
- (D) shield volcanism

15. Mesas are common in the

- (A) Eastern Ghats granulite belt
- (B) Himalayan mountain range
- (C) Deccan Traps
- (D) Dharwar greenstone belt

16. Chromite deposits result from

- (A) early magmatic dissemination
- (B) early magmatic segregation
- (C) early magmatic injection
- (D) late magmatic residual fluid injection

17. In a normal stratigraphic sequence, erosion can sometimes expose older rocks within younger rocks. Such exposures are called

- (A) inlier
- (B) window
- (C) outlier
- (D) klippe

18. The largest known kyanite deposit in the world is in

- (A) Jharkhand
- (B) Bihar
- (C) Assam
- (D) Tamil Nadu

19. Match the following

**Group I**

- (P) Lameta Formation
- (Q) Raniganj Formation
- (R) Pinjor Formation
- (S) Umria Marine Beds

**Group II**

- (1) *Elephas*
- (2) *Glossopteris*
- (3) *Titanosaurus*
- (4) *Productus*

- |     |       |       |       |       |
|-----|-------|-------|-------|-------|
| (A) | P – 4 | Q – 1 | R – 2 | S – 3 |
| (B) | P – 1 | Q – 3 | R – 4 | S – 2 |
| (C) | P – 2 | Q – 1 | R – 3 | S – 4 |
| (D) | P – 3 | Q – 2 | R – 1 | S – 4 |

20. Ophiolitic mélange is characteristic of

- (A) Lesser Himalaya
- (B) Higher Himalaya
- (C) Outer Himalaya
- (D) Indus Suture Zone

21. The angle between the “Y” vibration direction and the optic axis of a monoclinic mineral is

- (A) 0°
- (B) 45°
- (C) 90°
- (D) 102°

22. Identify the incorrect pair

- (A) Lithostratigraphy - Formation
- (B) Biostratigraphy - Interval Zone
- (C) Chronostratigraphy - Series
- (D) Geochronology - System

23. On a Survey of India toposheet number 53 V/3, a distance of four centimeters between two points represents an actual ground distance of

- (A) 1 km
- (B) 2 km
- (C) 8 km
- (D) 16 km

24. A rock that is porous but not permeable is

- (A) sandstone
- (B) siltstone
- (C) shale
- (D) marble

25. The upper mantle of the earth is composed largely of

- (A) peridotite
- (B) gabbro
- (C) mafic granulite
- (D) eclogite

26. Refer to the geological map, which shows the development of a metamorphic aureole around a granite intrusion in a sedimentary sequence. Which one of the following combinations of rocks exposed at locations X, Y and Z is correct?

- |     | X         | Y         | Z         |
|-----|-----------|-----------|-----------|
| (A) | marble    | quartzite | hornfels  |
| (B) | quartzite | hornfels  | marble    |
| (C) | hornfels  | quartzite | marble    |
| (D) | marble    | hornfels  | quartzite |

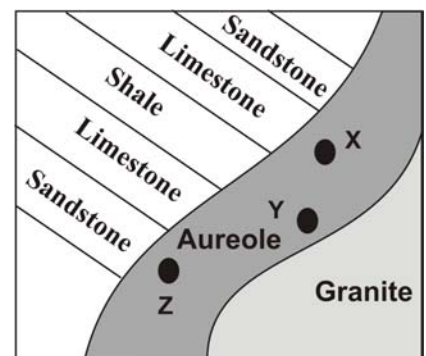

27. Match the following

<b>Group I</b>		<b>Group II</b>		
(P)	Oil	(1)	Bokaro	
(Q)	Coal	(2)	Zawar	
(R)	Lead – zinc	(3)	Jamar Kotra	
(S)	Phosphate	(4)	Ankleshwar	
(A)	P – 1	Q – 3	R – 2	S – 4
(B)	P – 2	Q – 4	R – 3	S – 1
(C)	P – 4	Q – 1	R – 3	S – 2
(D)	P – 4	Q – 1	R – 2	S – 3

28. Which one of the following series of rock formations is arranged in the correct stratigraphic order (i.e. from older to younger) ?

- (A) Malani volcanics - Panjal volcanics – Rajmahal volcanics – Deccan volcanics  
 (B) Dhokpathan – Tatrot – Boulder Conglomerate – Pinjor  
 (C) Uttatur – Ariyalur – Niniyur – Trichinopoly  
 (D) Talchir – Panchet – Damuda – Mahadeva

29. Match the following

- Group I**  
 (P) Plunging antiform  
 (Q) Plunging synform  
 (R) Recumbent fold  
 (S) Reclined fold

**Group II**

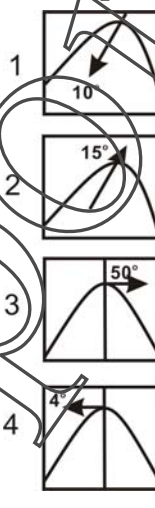

(A)	P – 1	Q – 2	R – 3	S – 4
(B)	P – 2	Q – 1	R – 4	S – 3
(C)	P – 3	Q – 4	R – 1	S – 2
(D)	P – 4	Q – 3	R – 2	S – 1

30. The method applied for isotope dating of the Holocene rocks involves

- (A) K – Ar  
 (B)  $C^{14}$   
 (C) U – Pb  
 (D) Rb - Sr

31. Answer the following with neat sketches

- (a) (i) What is a meandering stream ? (3)  
 (ii) Indicate the sites of erosion and deposition in it. (3+3)  
 (b) How is an oxbow lake formed? (6)

32. (a) A mineral belonging to the hexagonal crystal system is optically negative with principal indices of refraction 1.486 and 1.658. Answer the following.

- (i) What is the maximum birefringence of the mineral? (3)  
 (ii) Giving reason, state the value of  $n_{\omega}$  ? (3)

- (b) (i) Draw and label the interference figure of the above mineral for orientation perpendicular to the  $c$  – axis. Show vibration directions of the ordinary and extraordinary rays in all the quadrants. (3+3)
- (ii) Which three optical properties do you study in section parallel to (010) of a monoclinic crystal? (3)
33. (a) (i) What is an aquifer? (3)
- (ii) Define the term ‘water table’. (3)
- (iii) Draw a neat, labeled sketch to show perched water table (3)
- (b) (i) Define a confined aquifer. (3)
- (ii) Define an aquifuge. (3)
34. (a) (i) Draw a labeled diagram to show the earth’s ‘S-wave shadow zone’. (6)
- (ii) Mention its significance. (3)
- (b) Name the submarine mechanisms that can trigger a ‘Tsunami’. (6)
35. The map below shows the outcrop pattern of a folded sequence of beds A, B, C and D. Also shown is the projected cross bed in the north-western part of the map.
- (a) (i) Interpret the structure. (6)
- (ii) Locate the possible hinge zone on the map, and give justification. (3)
- (b) Draw a section along X-Y and establish the stratigraphic sequence, based on the assumption that there is no stratigraphic inversion of strata. (3+3)

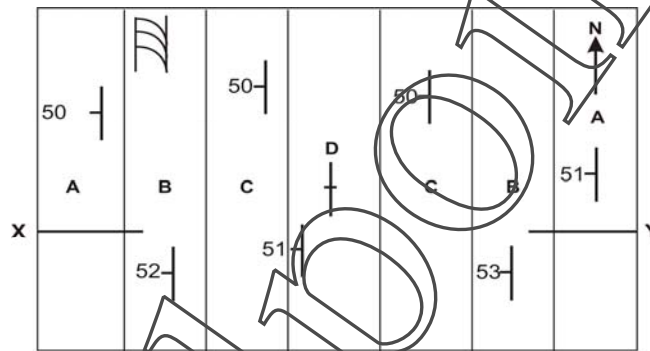

36. The geological map shows the outcrop pattern of the first appearance of mineral/mineral assemblage in metamorphic rocks of fixed bulk composition. Answer the following questions.

- (a) (i) What is the protolith of these rocks? (3)
- (ii) What are these lines called? (3)
- (iii) Name a model metamorphic reaction, which produces K-feldspar-sillimanite assemblage. (3)

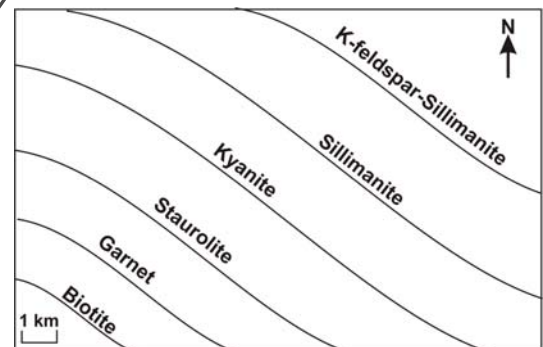

- (b) (i) Name the metamorphic facies series and the tectonic setting, which explain the occurrence of these minerals. (3)
- (ii) Can garnet reappear in any other part of the metamorphic sequence? Justify. (3)

37. The cross-section below shows the relationship between different igneous features. Also shown are the igneous textures related to some of these igneous features.

- (a) (i) Name the igneous features in locales B, C and D. (3)
- (ii) Identify the igneous textures in A and B. (3)
- (iii) Name the rocks at A, B and D. (3)

(b) What causes textural variation in rocks A, B and D?

(6)

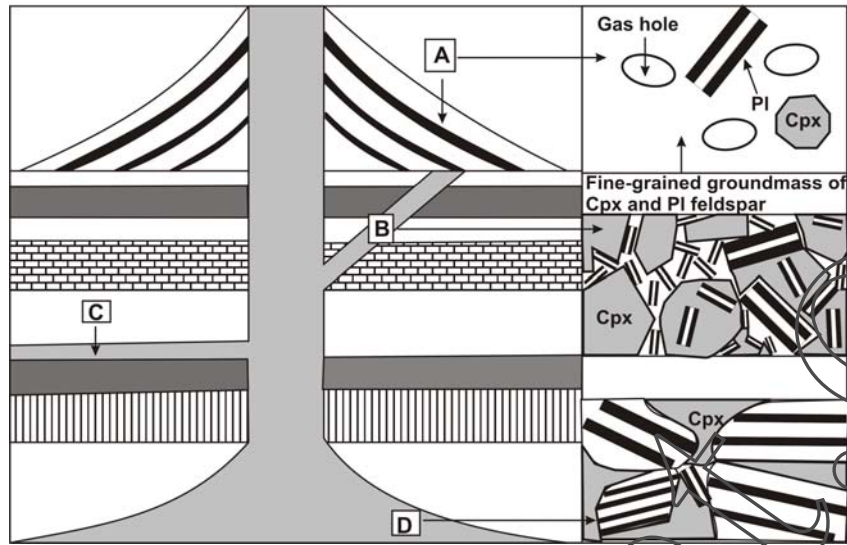

38. Study the isobaric binary phase diagram of  $\text{NaAlSi}_3\text{O}_8$  -  $\text{SiO}_2$  given below and answer the following questions.

(i) Find out the mineral assemblages in A, B, C, D, and the line Y and composition X.

(9)

(ii) Using this diagram, explain why nepheline and quartz do not co-exist in nepheline syenite.

(6)

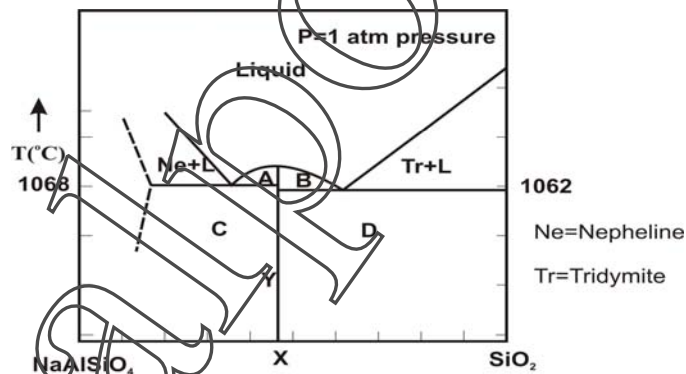

39. (a) Name the three main suture types found in ammonoid cephalopods, and give labeled diagrams for each.

(3+3+3)

(b) (i) How does a brachiopod shell differ from a pelecypod shell with respect to the valve size and the plane of symmetry?

(3)

(ii) Name one formation known for yielding late Cretaceous dinosaurs in India.

(3)

40. (a) Name the following

(i) Precambrian basement underlying the Proterozoic succession in the Aravalli belt.

(3)

(ii) Early Cretaceous continental flood basalts in Peninsular India.

(3)

(iii) Youngest formation of the Siwalik Group.

(3)

(b) Name the following

(i) Any three chronostratigraphic units and their corresponding geochronologic equivalents.

(3)

(ii) The three successive tectonic divisions of the Himalaya starting from the southernmost division.

(3)



41. (a) (i) Why does a  $\text{SiO}_4$  tetrahedra never share edges or faces with its neighbouring tetrahedra ? (3)  
 (ii) Why does a five -, seven - or ten - fold symmetry not exist in crystals? (3)  
 (iii) Deduce the H-M symbol from the stereogram given below. (3)

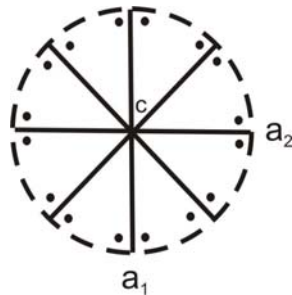

- b) (i) State three reasons that can cause twinning in minerals. (3)  
 (ii) What is a twin law? (3)
- 42 a) (i) What is sublimation process?  
 (ii) What are stockwork and saddle reef ore deposits?  
 (iii) Name at least three common surface mining methods. (3+3+3)
- b) (i) What are eluvial placer deposits? (3)  
 (ii) Name any two lignite deposits of India. (3)
43. (a) Define  
 (i) throw and heave of a fault.  
 (ii) disconformity and nonconformity. (3+3)
- (b) A sequence of beds A, B and C dipping due west, is affected by a vertical strike fault with downthrown block to the east. If the fault is passing through the western- most bed, show the effect of faulting and erosion on the outcrop pattern through block diagrams (9)
44. (a) Draw a labeled diagram to show three major plate boundaries. (3+3+3)  
 (b) Mention the four evidences for continental drift. (6)