





JAM 2015: General Instructions during Examination

- Total duration of the JAM 2015 examination is **180** minutes.
- The clock will be set at the server. The countdown timer at the top right corner of screen will display the remaining time available for you to complete the examination. When the timer reaches zero, the examination will end by itself. You need not terminate the examination or submit your paper.
- Any useful data required for your paper can be viewed by clicking on the **Useful Data** button that appears on the screen.
- Use the scribble pad provided to you for any rough work. Submit the scribble pad at the end of the examination.
- You are allowed to use only your own **non-programmable calculator**.
- The Question Palette displayed on the right side of screen will show the status of each question using one of the following symbols:

-  You have not visited the question yet.
-  You have not answered the question.
-  You have answered the question.
-  You have NOT answered the question, but have marked the question for review.
-  You have answered the question, but marked it for review.

- The **Marked for Review** status for a question simply indicates that you would like to look at that question again. *If a question is 'answered, but marked for review', then the answer will be considered for evaluation unless the status is modified by the candidate.*

Navigating to a Question :

- To answer a question, do the following:
 - Click on the question number in the Question Palette to go to that question directly.
 - Select the answer for a multiple choice type question and for the multiple select type question. Use the virtual numeric keypad to enter the answer for a numerical type question.
 - Click on **Save & Next** to save your answer for the current question and then go to the next question.
 - Click on **Mark for Review & Next** to save and to mark for review your answer for the current question, and then go to the next question.

Caution: Note that your answer for the current question will not be saved, if you navigate to another question directly by clicking on a question number **without saving** the answer to the previous question.

- You can view all the questions by clicking on the **Question Paper** button. **This feature is provided, so that if you want you can just see the entire question paper at a glance.**

Answering a Question :

- Procedure for answering a multiple choice question (MCQ):
 - Choose the answer by selecting **only one out of the 4 choices** (A,B,C,D) given below the question and click on the bubble placed before the selected choice.

- b. To deselect your chosen answer, click on the bubble of the selected choice again or click on the **Clear Response** button.
 - c. To change your chosen answer, click on the bubble of another choice.
 - d. To save your answer, you **MUST** click on the **Save & Next** button.
11. Procedure for answering a multiple select question (MSQ):
- a. Choose the answer by selecting **one or more than one out of the 4** choices (A,B,C,D) given below the question and click on the checkbox(es) placed before each of the selected choice(s).
 - b. To deselect one or more of your selected choice(s), click on the checkbox(es) of the choice(s) again. To deselect all the selected choices, click on the **Clear Response** button.
 - c. To change a particular selected choice, deselect this choice that you want to change and click on the checkbox of another choice.
 - d. To save your answer, you **MUST** click on the **Save & Next** button.
12. Procedure for answering a numerical answer type (NAT) question:
- a. To enter **a number** as your answer, use the virtual numerical keypad.
 - b. A fraction (e.g. -0.3 or -.3) can be entered as an answer with or without $\frac{\square}{\square}$ before the decimal point. As many as four decimal points, e.g. 12.5435 or 0.003 or 932.6711 or 12.82 can be entered.
 - c. To clear your answer, click on the **Clear Response** button.
 - d. To save your answer, you **MUST** click on the **Save & Next** button.
13. To mark a question for review, click on the **Mark for Review & Next** button. *If an answer is selected (for MCQ and MSQ types) or entered (for NAT) for a question that is **Marked for Review**, that answer will be considered in the evaluation unless the status is modified by the candidate.*
14. To change your answer to a question that has already been answered, first select that question and then follow the procedure for answering that type of question as described above.
15. Note that **ONLY** those questions for which answers are **saved** or **marked for review after answering** will be considered for evaluation.

Choosing a Section :

16. Sections in this question paper are displayed on the top bar of the screen. **All sections are compulsory.**
17. Questions in a section can be viewed by clicking on the name of that section. The section you are currently viewing will be highlighted.
18. To select another section, simply click the name of the section on the top bar. You can shuffle between different sections any number of times.
19. When you select a section, you will only be able to see questions in this Section, and you can answer questions in the Section.
20. After clicking the **Save & Next** button for the last question in a section, you will automatically be taken to the first question of the next section in sequence.
21. You can move the mouse cursor over the name of a section to view the answering status for that section.

JAM 2015 Examination

PH: Physics

Duration: 180 minutes

Maximum Marks: 100

Read the following instructions carefully.

1. To login, enter your Registration Number and Password provided to you. Kindly go through the various coloured symbols used in the test and understand their meaning before you start the examination.
2. Once you login and after the start of the examination, you can view all the questions in the question paper, by clicking on the **Question Paper** button in the screen.
3. This test paper has a total of 60 questions carrying 100 marks. The entire question paper is divided into three **sections, A, B and C**. All sections are compulsory. Questions in each section are of different types.
4. **Section – A** contains **Multiple Choice Questions (MCQ)**. Each MCQ type question has four choices out of which only one choice is the correct answer. This section has 30 Questions and carry a total of 50 marks. Q.1 – Q.10 carry 1 mark each and Questions Q.11 – Q.30 carry 2 marks each.
5. **Section – B** contains **Multiple Select Questions (MSQ)**. Each MSQ type question is similar to MCQ but with a difference that there may be one or more than one choice(s) that are correct out of the four given choices. The candidate gets full credit if he/she selects all the correct choices only and no wrong choices. This section has 10 Questions and carry 2 marks each with a total of 20 marks.
6. **Section – C** contains **Numerical Answer Type (NAT)** questions. For these NAT type questions, the answer is a real number which needs to be entered using the virtual numerical keypad on the monitor. No choices will be shown for these type of questions. This section has 20 Questions and carry a total of 30 marks. Q.1 – Q.10 carry 1 mark each and Questions Q.11 – Q.20 carry 2 marks each.
7. Depending upon the JAM test paper, there may be useful common data that may be required for answering the questions. If the paper has such useful data, the same can be viewed by clicking on the **Useful Data** button that appears at the top, right hand side of the screen.
8. The computer allotted to you at the examination centre runs specialized software that permits only one choice to be selected as answer for multiple choice questions using a mouse, one or more than one choices to be selected as answer for multiple select questions using a mouse and to enter a suitable number for the numerical answer type questions using the virtual numeric keypad and mouse.
9. Your answers shall be updated and saved on a server periodically and also at the end of the examination. The examination will **stop automatically** at the end of **180 minutes**.
10. Multiple choice questions (Section-A) will have four choices against A, B, C, D, out of which only **ONE** choice is the correct answer. The candidate has to choose the correct answer by clicking on the bubble (○) placed before the choice.
11. Multiple select questions (Section-B) will also have four choices against A, B, C, D, out of which **ONE OR MORE THAN ONE** choice(s) is /are the correct answer. The candidate has to choose the correct answer by clicking on the checkbox (☐) placed before the choices for each of the selected choice(s).
12. For numerical answer type questions (Section-C), each question will have a numerical answer and there will not be any choices. **For these questions, the answer should be entered** by using the mouse and the virtual numerical keypad that appears on the monitor.
13. In all questions, questions not attempted will result in zero mark. In **Section – A** (MCQ), wrong answer will result in **NEGATIVE** marks. For all 1 mark questions, 1/3 marks will be deducted for each wrong answer. For all 2 marks questions, 2/3 marks will be deducted for each wrong answer. In **Section – B** (MSQ), there is **NO NEGATIVE** and **NO PARTIAL** marking provisions. There is **NO NEGATIVE** marking in **Section – C** (NAT) as well.

14. **Non-programmable calculators** are allowed but sharing of calculators is not allowed.
15. Mobile phones, electronic gadgets other than calculators, charts, graph sheets, and mathematical tables are **NOT** allowed in the examination hall.
16. You can use the scribble pad provided to you at the examination centre for all your rough work. The scribble pad has to be returned at the end of the examination.

Declaration by the candidate:

"I have read and understood all the above instructions. I have also read and understood clearly the instructions given on the admit card and shall follow the same. I also understand that in case I am found to violate any of these instructions, my candidature is liable to be cancelled. I also confirm that at the start of the examination all the computer hardware allotted to me are in proper working condition".

Useful Data

Speed of light in vacuum (c): $3 \times 10^8 \text{ m s}^{-1}$

Planck's constant (h): $6.62 \times 10^{-34} \text{ J s}$

h bar times speed of light in vacuum ($\hbar c$): $200 \times 10^{-15} \text{ MeV m}$

Universal gas constant (R): $8.3 \text{ J K}^{-1} \text{ mole}^{-1}$

Mass of the electron (m_e): $9.1 \times 10^{-31} \text{ Kg}$

Charge of the electron (e): $-1.6 \times 10^{-19} \text{ C}$

Acceleration due to gravity (g): 9.8 m s^{-2}

Free space permittivity (ϵ_0): $8.85 \times 10^{-12} \text{ N m}^2 \text{ C}^{-2}$

In multiple choice questions having numerical answers, choose the option nearest to the correct answer.

SECTION – A
MULTIPLE CHOICE QUESTIONS (MCQ)

Q. 1 – Q.10 carry one mark each.

Q.1 A system consists of N number of particles, $N \gg 1$. Each particle can have only one of the two energies E_1 or $E_1 + \varepsilon$ ($\varepsilon > 0$). If the system is in equilibrium at a temperature T , the average number of particles with energy E_1 is

- (A) $\frac{N}{2}$
 (B) $\frac{N}{e^{\varepsilon/kT} + 1}$
 (C) $\frac{N}{e^{-\varepsilon/kT} + 1}$
 (D) $Ne^{-\varepsilon/kT}$

Q.2 A mass m , lying on a horizontal, frictionless surface, is connected to one end of a spring. The other end of the spring is connected to a wall, as shown in the figure. At $t = 0$, the mass is given an impulse.

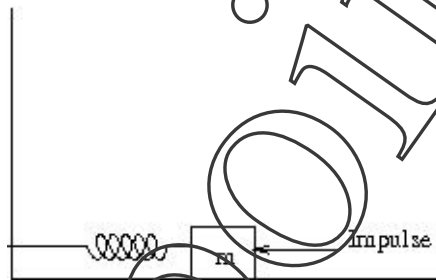

The time dependence of the displacement and the velocity of the mass (in terms of non-zero constants A and B) are given by

- (A) $x(t) = A \sin \omega t, v(t) = B \cos \omega t$
 (B) $x(t) = A \sin \omega t, v(t) = B \sin \omega t$
 (C) $x(t) = A \cos \omega t, v(t) = B \sin \omega t$
 (D) $x(t) = A \cos \omega t, v(t) = B \cos \omega t$

Q.3 A particle with energy E is incident on a potential given by

$$V(x) = \begin{cases} 0, & x < 0 \\ V_0, & x \geq 0 \end{cases}$$

The wave function of the particle for $E < V_0$, in the region $x > 0$ (in terms of positive constants A , B and k) is

- (A) $Ae^{kx} + Be^{-kx}$
 (B) Ae^{-kx}
 (C) $Ae^{ikx} + Be^{-ikx}$
 (D) Zero

- Q.4 The electric field of a light wave is given by $\vec{E} = E_0[\hat{i} \sin(\omega t - kz) + \hat{j} \sin(\omega t - kz - \frac{\pi}{4})]$. The polarization state of the wave is
- (A) Left handed circular
 (B) Right handed circular
 (C) Left handed elliptical
 (D) Right handed elliptical
- Q.5 Consider the coordinate transformation $x' = \frac{x+y}{\sqrt{2}}, y' = \frac{x-y}{\sqrt{2}}$. The relation between the area elements $dx'dy'$ and $dx dy$ is given by $dx'dy' = J dx dy$. The value of J is
- (A) 2 (B) 1 (C) -1 (D) -2
- Q.6 The trace of a 2×2 matrix is 4 and its determinant is 8. If one of the eigenvalues is $2(1 + i)$, the other eigenvalue is
- (A) $2(1 - i)$ (B) $2(1 + i)$ (C) $(1 + 2i)$ (D) $(1 - 2i)$
- Q.7 Temperature dependence of resistivity of a metal can be described by

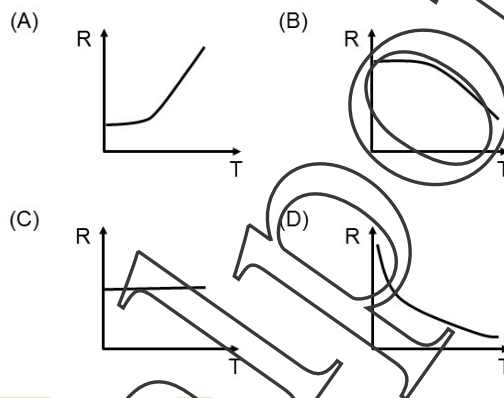

- Q.8 A proton from outer space is moving towards earth with velocity $0.99c$ as measured in earth's frame. A spaceship, traveling parallel to the proton, measures proton's velocity to be $0.97c$. The approximate velocity of the spaceship, in the earth's frame, is
- (A) $0.2c$ (B) $0.3c$
 (C) $0.4c$ (D) $0.5c$
- Q.9 A charge q is at the center of two concentric spheres. The outward electric flux through the inner sphere is ϕ while that through the outer sphere is 2ϕ . The amount of charge contained in the region between the two spheres is
- (A) $2q$ (B) q (C) $-q$ (D) $-2q$

- Q.10 At room temperature, the speed of sound in air is 340 m/sec. An organ pipe with both ends open has a length $L = 29$ cm. An extra hole is created at the position $L/2$. The lowest frequency of sound produced is
- (A) 293 Hz (B) 586 Hz (C) 1172 Hz (D) 2344 Hz

Q. 11 – Q. 30 carry two marks each.

- Q.11 A system comprises of three electrons. There are three single particle energy levels accessible to each of these electrons. The number of possible configurations for this system is
- (A) 1 (B) 3 (C) 6 (D) 7
- Q.12 A rigid and thermally isolated tank is divided into two compartments of equal volume V , separated by a thin membrane. One compartment contains one mole of an ideal gas A and the other compartment contains one mole of a different ideal gas B. The two gases are in thermal equilibrium at a temperature T . If the membrane ruptures, the two gases mix. Assume that the gases are chemically inert. The change in the total entropy of the gases on mixing is
- (A) 0 (B) $R \ln 2$ (C) $\frac{3}{2} R \ln 2$ (D) $2R \ln 2$
- Q.13 A Zener regulator has an input voltage in the range 15V-20V and a load current in the range of 5 mA-20 mA. If the Zener voltage is 6.8V, the value of the series resistor should be

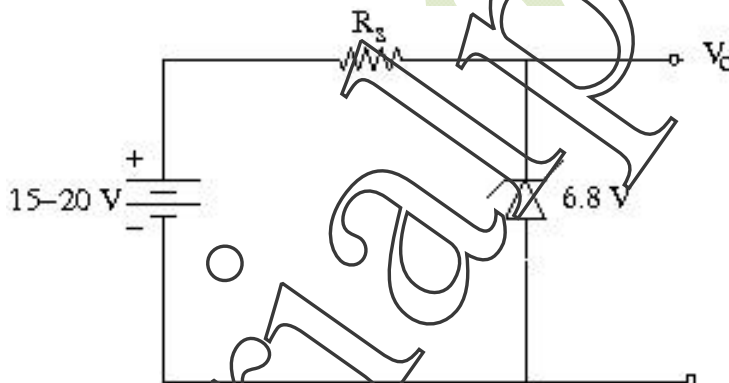

- (A) 390 Ω (B) 420 Ω
 (C) 440 Ω (D) 460 Ω

- Q.14 The variation of binding energy per nucleon with respect to the mass number of nuclei is shown in the figure.

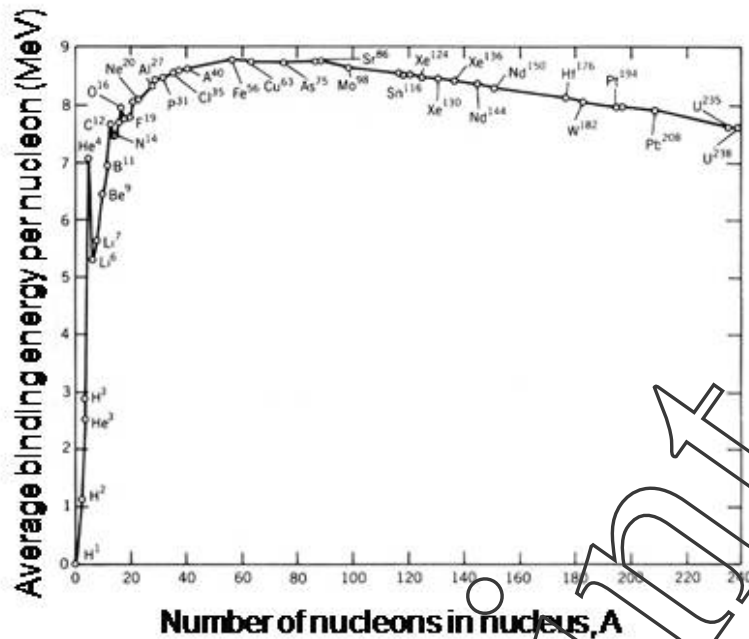

Consider the following reactions:

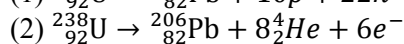
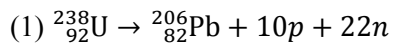

Which one of the following statements is true for the given decay modes of ${}_{92}^{238}\text{U}$?

- (A) Both (1) and (2) are allowed
 (B) Both (1) and (2) are forbidden
 (C) (1) is forbidden and (2) is allowed
 (D) (1) is allowed and (2) is forbidden

- Q.15 A rigid triangular molecule consists of three non-collinear atoms joined by rigid rods. The constant pressure molar specific heat (C_p) of an ideal gas consisting of such molecules is

- (A) $6R$
 (B) $5R$
 (C) $4R$
 (D) $3R$

- Q.16 A satellite moves around the earth in a circular orbit of radius R centered at the earth. A second satellite moves in an elliptic orbit of major axis $8R$, with the earth at one of the foci. If the former takes 1 day to complete a revolution, the latter would take

- (A) 21.6 days (B) 8 days (C) 3 hours (D) 1.1 hour

Q.17 A positively charged particle, with a charge q , enters a region in which there is a uniform electric field \vec{E} and a uniform magnetic field \vec{B} , both directed parallel to the positive y -axis. At $t = 0$, the particle is at the origin and has a speed v_0 directed along the positive x -axis. The orbit of the particle, projected on the x - z plane, is a circle. Let T be the time taken to complete one revolution of this circle. The y -coordinate of the particle at $t = T$ is given by

- (A) $\frac{\pi^2 m E}{2 q B^2}$ (B) $\frac{2 \pi^2 m E}{q B^2}$
 (C) $\frac{\pi^2 m E}{q B^2} + \frac{v_0 \pi m}{q B}$ (D) $\frac{2 \pi m v_0}{q B}$

Q.18 Vibrations of diatomic molecules can be represented as those of harmonic oscillators. Two halogen molecules X_2 and Y_2 have fundamental vibrational frequencies $\nu_X = 16.7 \times 10^{12}$ Hz and $\nu_Y = 26.8 \times 10^{12}$ Hz, respectively. The respective force constants are $K_X = 325$ N/m and $K_Y = 446$ N/m. The atomic masses of F, Cl and Br are 19.0, 35.5 and 79.9 atomic mass unit respectively. The halogen molecules X_2 and Y_2 are

- (A) $X_2 = F_2$ and $Y_2 = Cl_2$ (B) $X_2 = Cl_2$ and $Y_2 = F_2$
 (C) $X_2 = Br_2$ and $Y_2 = F_2$ (D) $X_2 = F_2$ and $Y_2 = Br_2$

Q.19 A hollow, conducting spherical shell of inner radius R_1 and outer radius R_2 encloses a charge q inside, which is located at a distance d ($< R_1$) from the centre of the spheres. The potential at the centre of the shell is

- (A) Zero (B) $\frac{1}{4\pi\epsilon_0} \frac{q}{d}$
 (C) $\frac{1}{4\pi\epsilon_0} \left(\frac{q}{d} - \frac{q}{R_1} \right)$ (D) $\frac{1}{4\pi\epsilon_0} \left(\frac{q}{d} - \frac{q}{R_1} + \frac{q}{R_2} \right)$

Q.20 Doppler effect can be used to measure the speed of blood through vessels. Sound of frequency 1.0522 MHz is sent through the vessels along the direction of blood flow. The reflected sound generates a beat signal of frequency 100 Hz. The speed of sound in blood is 1545 m/sec. The speed of blood through the vessel, in m/sec, is

- (A) 14.68 (B) 1.468 (C) 0.1468 (D) 0.01468

Q.21 Which of the following circuits represent the Boolean expression

$$S = \overline{P + QR} + \overline{Q}P$$

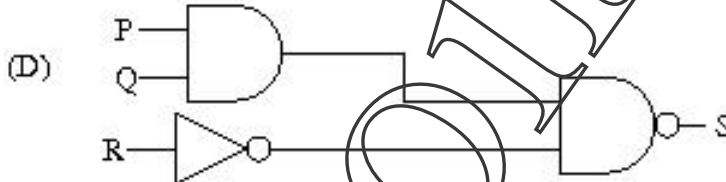
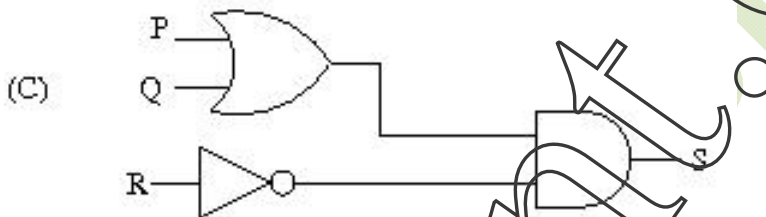
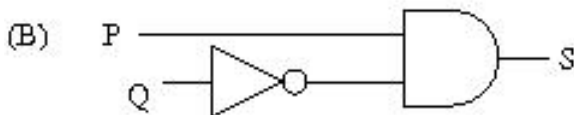
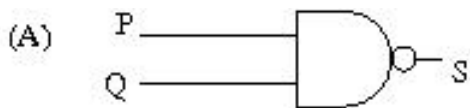

Q.22 A conducting wire is in the shape of a regular hexagon, which is inscribed inside an imaginary circle of radius R, as shown. A current I flows through the wire. The magnitude of the magnetic field at the center of the circle is

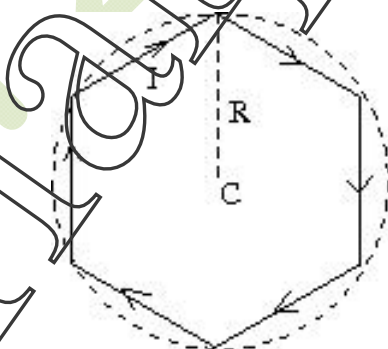

(A) $\frac{\sqrt{3}\mu_0 I}{2\pi R}$
 (C) $\frac{\sqrt{3}\mu_0 I}{\pi R}$

(B) $\frac{\mu_0 I}{2\sqrt{3}\pi R}$
 (D) $\frac{3\mu_0 I}{2\pi R}$

- Q.23 An observer is located on a horizontal, circular turntable which rotates about a vertical axis passing through its center, with a uniform angular speed of 2 rad/sec. A mass of 10 grams is sliding without friction on the turntable. At an instant when the mass is at a distance of 8 cm from the axis, it is observed to move towards the center with a speed of 6 cm/sec. The net force on the mass, as seen by the observer at that instant, is
- (A) 0.0024 N (B) 0.0032 N
(C) 0.004 N (D) 0.006 N
- Q.24 Miller indices of a plane in cubic structure that contains all the directions $[100]$, $[011]$ and $[111]$ are
- (A) (011) (B) (101) (C) (100) (D) (110)
- Q.25 Seven uniform disks, each of mass m and radius r , are inscribed inside a regular hexagon, as shown. The moment of inertia of this system of seven disks, about an axis passing through the central disk and perpendicular to the plane of the disks, is

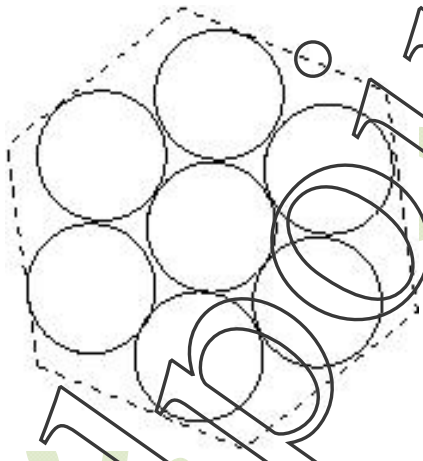

- (A) $\frac{7}{2}mr^2$ (B) $7mr^2$ (C) $\frac{17}{2}mr^2$ (D) $\frac{55}{2}mr^2$
- Q.26 A nucleus has a size of 10^{-15} m. Consider an electron bound within a nucleus. The estimated energy of this electron is of the order of
- (A) 1 MeV (B) 10^2 MeV
(C) 10^4 MeV (D) 10^6 MeV
- Q.27 Consider a vector field $\vec{F} = y\hat{i} + xz^3\hat{j} - zy\hat{k}$. Let C be the circle $x^2 + y^2 = 4$ on the plane $z = 2$, oriented counter-clockwise. The value of the contour integral $\oint_C \vec{F} \cdot d\vec{r}$ is
- (A) 28π (B) 4π (C) -4π (D) -28π
- Q.28 Consider the equation $\frac{dy}{dx} = \frac{y^2}{x}$ with the boundary condition $y(1) = 1$. Out of the following, the range of x in which y is real and finite, is
- (A) $-\infty \leq x \leq -3$ (B) $-3 \leq x \leq 0$
(C) $0 \leq x \leq 3$ (D) $3 \leq x \leq \infty$

- Q.29 The Fourier series for an arbitrary periodic function with period $2L$ is given by $f(x) = \frac{a_0}{2} + \sum_{n=1}^{\infty} a_n \cos \frac{n\pi x}{L} + \sum_{n=1}^{\infty} b_n \sin \frac{n\pi x}{L}$. For the particular periodic function shown in the figure, the value of a_0 is

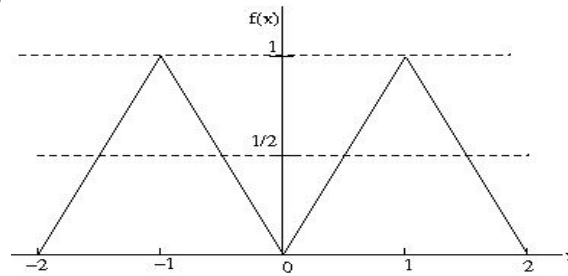

- (A) 0 (B) 0.5 (C) 1 (D) 2
- Q.30 The phase of the complex number $(1 + i)i$ in the polar representation is

- (A) $\pi/4$ (B) $\pi/2$
 (C) $3\pi/4$ (D) $5\pi/4$

SECTION - B

MULTIPLE SELECT QUESTIONS (MSQ)

Q. 1 – Q. 10 carry two marks each.

- Q.1 For an electromagnetic wave traveling in free space, the electric field is given by $\vec{E} = 100 \cos(10^8 t + kx) \hat{j}$ V/m. Which of the following statements are true?
- (A) The wavelength of the wave in meter is 6π
 (B) The corresponding magnetic field is directed along the positive z direction
 (C) The Poynting vector is directed along the positive z direction
 (D) The wave is linearly polarized

- Q.2 In an ideal Op-Amp circuit shown below, $R_1=3\text{k}\Omega$, $R_2=1\text{k}\Omega$ and $V_i = 0.5 \sin \omega t$ (in Volt). Which of the following statements are true?

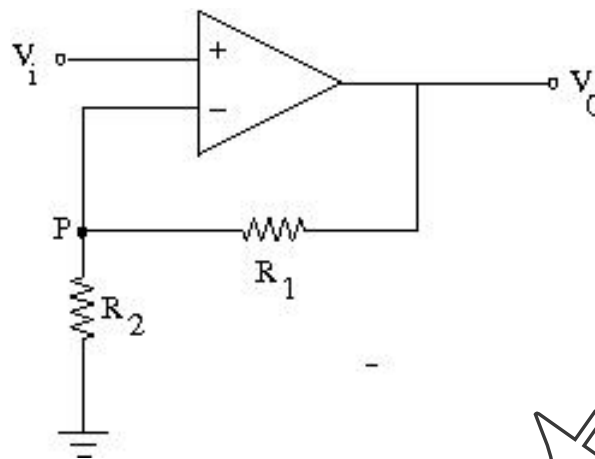

- (A) The current through R_1 = The current through R_2
 (B) The potential at P is $V_0 \frac{R_2}{R_1}$
 (C) The amplitude of V_0 is 2V
 (D) The output voltage V_0 is in phase with V_i
- Q.3 A particle of mass m is moving in x-y plane. At any given time t , its position vector is given by $\vec{r}(t) = A \cos \omega t \hat{i} + B \sin \omega t \hat{j}$, where A, B and ω are constants with $A \neq B$. Which of the following statements are true?
- (A) Orbit of the particle is an ellipse
 (B) Speed of the particle is constant
 (C) At any given time t , the particle experiences a force towards origin
 (D) The angular momentum of the particle is $m\omega AB \hat{k}$
- Q.4 A rod is hanging vertically from a pivot. A particle, traveling in horizontal direction, collides with the rod as shown in the figure. For the rod-particle system, consider the linear momentum and the angular momentum about the pivot. Which of the following statements are **NOT** true?

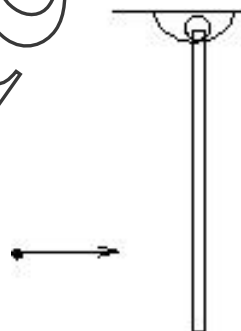

- (A) Both linear momentum and angular momentum are conserved
 (B) Linear momentum is conserved but angular momentum is not
 (C) Linear momentum is not conserved but angular momentum is conserved
 (D) Neither linear momentum nor angular momentum are conserved

Q.5 A particle is moving in a two-dimensional potential well

$$V(x, y) = 0, \quad 0 \leq x \leq L, 0 \leq y \leq 2L$$

$$= \infty, \quad \text{elsewhere.}$$

Which of the following statements about the ground state energy E_1 and ground state eigenfunction φ_0 are true?

(A) $E_1 = \frac{\hbar^2 \pi^2}{mL^2}$

(B) $E_1 = \frac{5\hbar^2 \pi^2}{8mL^2}$

(C) $\varphi_0 = \frac{\sqrt{2}}{L} \sin \frac{\pi x}{L} \sin \frac{\pi y}{2L}$

(D) $\varphi_0 = \frac{\sqrt{2}}{L} \cos \frac{\pi x}{L} \cos \frac{\pi y}{2L}$

Q.6 Consider the circuit, consisting of an AC function generator $V(t) = V_0 \sin 2\pi vt$ with $V_0 = 5V$, an inductor $L = 8.0 \text{ mH}$, resistor $R = 5 \Omega$ and a capacitor $C = 100 \mu F$. Which of the following statements are true if we vary the frequency?

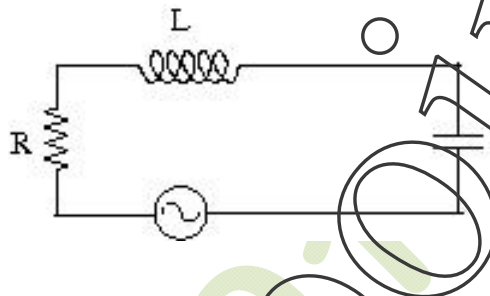

- (A) The current in the circuit would be maximum at $v = 178 \text{ Hz}$
 (B) The capacitive reactance increases with frequency
 (C) At resonance, the impedance of the circuit is equal to the resistance in the circuit
 (D) At resonance, the current in the circuit is out of phase with the source voltage

Q.7 Muons are elementary particles produced in the upper atmosphere. They have a life time of $2.2 \mu s$. Consider muons which are traveling vertically towards the earth's surface at a speed of $0.998c$. For an observer on earth, the height of the atmosphere above the surface of the earth is 10.4 km . Which of the following statements are true?

- (A) The muons can never reach earth's surface
 (B) The apparent thickness of earth's atmosphere in muon's frame of reference is 0.96 km
 (C) The lifetime of muons in earth's frame of reference is $34.8 \mu s$
 (D) Muons traveling at a speed greater than $0.998c$ reach the earth's surface

- Q.8 As shown in the P-V diagram, AB and CD are two isotherms at temperatures T_1 and T_2 , respectively ($T_1 > T_2$). AC and BD are two reversible adiabats. In this Carnot cycle, which of the following statements are true?

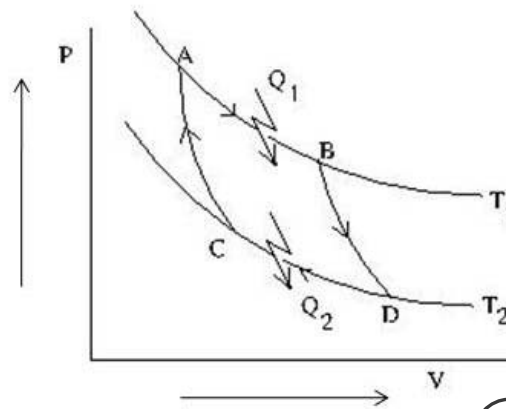

- (A) $\frac{Q_1}{T_1} = \frac{Q_2}{T_2}$ (B) The entropy of the source decreases
 (C) The entropy of the system increases (D) Work done by the system $W = Q_1 - Q_2$
- Q.9 The following figure shows a double slit Fraunhofer diffraction pattern produced by two slits, each of width a , separated by a distance b , $a < b$. Which of the following statements are correct?

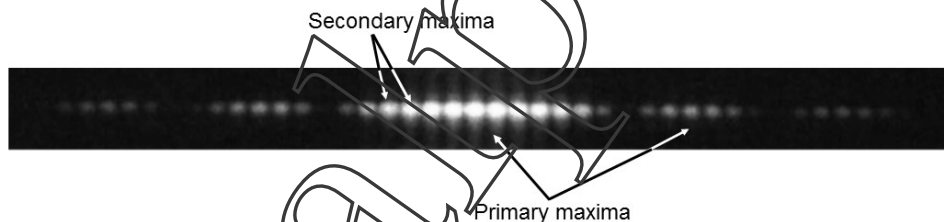

- (A) Reducing a increases the separation between consecutive primary maxima
 (B) Reducing a increases the separation between consecutive secondary maxima
 (C) Reducing b increases the separation between consecutive primary maxima
 (D) Reducing b increases the separation between consecutive secondary maxima
- Q.10 A unit cube made of a dielectric material has a polarization $\vec{P} = 3\hat{i} + 4\hat{j}$ units. The edges of the cube are parallel to the Cartesian axes. Which of the following statements are true?
- (A) The cube carries a volume bound charge of magnitude 5 units
 (B) There is a charge of magnitude 3 units on both the surfaces parallel to the y-z plane
 (C) There is a charge of magnitude 4 units on both the surfaces parallel to the x-z plane
 (D) There is a net non-zero induced charge on the cube

SECTION – C

NUMERICAL ANSWER TYPE (NAT)

Q. 1 – Q. 10 carry one mark each.

- Q.1 The power radiated by sun is 3.8×10^{26} W and its radius is 7×10^5 km. The magnitude of the Poynting vector (in W/cm^2) at the surface of the sun is _____.
- Q.2 A particle is in a state which is a superposition of the ground state φ_0 and the first excited state φ_1 of a one-dimensional quantum harmonic oscillator. The state is given by $\Phi = \frac{1}{\sqrt{5}}\varphi_0 + \frac{2}{\sqrt{5}}\varphi_1$. The expectation value of the energy of the particle in this state (in units of $\hbar\omega$, ω being the frequency of the oscillator) is _____.
- Q.3 In an experiment on charging of an initially uncharged capacitor, an RC circuit is made with the resistance $R = 10 \text{ k}\Omega$ and the capacitor $C = 1000 \mu\text{F}$ along with a voltage source of 6V. The magnitude of the displacement current through the capacitor (in μA), 5 seconds after the charging has started, is _____.
- Q.4 In the given circuit, $V_{CC} = 10\text{V}$ and $\beta = 100$ for the n-p-n transistor. The collector voltage V_C (in Volts) is _____.

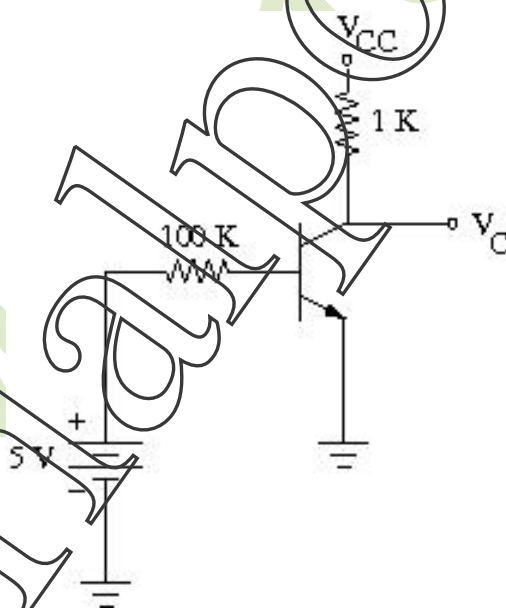

- Q.5 Unpolarized light is incident on a calcite plate at an angle of incidence 50° , as shown in the figure. Take $n_o = 1.6584$ and $n_e = 1.4864$ for calcite. The angular separation (in degrees) between the two emerging rays within the plate is _____.

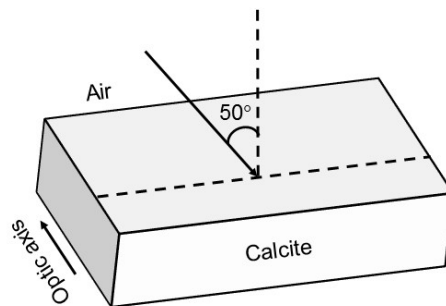

- Q.6 In the hydrogen atom spectrum, the ratio of the longest wavelength in the Lyman series (final state $n = 1$) to that in the Balmer series (final state $n = 2$) is _____.
- Q.7 A rod is moving with a speed of $0.8c$ in a direction at 60° to its own length. The percentage contraction in the length of the rod is _____.
- Q.8 X-rays of wavelength 0.24 nm are Compton scattered and the scattered beam is observed at an angle of 60° relative to the incident beam. The Compton wavelength of the electron is 0.00243 nm . The kinetic energy of scattered electrons in eV is _____.
- Q.9 A diode at room temperature ($kT = 0.025 \text{ eV}$) with a current of $1 \mu\text{A}$ has a forward bias voltage $V_F = 0.4 \text{ V}$. For $V_F = 0.5 \text{ V}$, the value of the diode current (in μA) is _____.
- Q.10 GaAs has a diamond structure. The number of Ga-As bonds per atom which have to be broken to fracture the crystal in the (001) plane is _____.

Q. 11 – Q. 20 carry two marks each.

- Q.11 In the thermodynamic cycle shown in the figure, one mole of a monatomic ideal gas is taken through a cycle. AB is a reversible isothermal expansion at a temperature of 800 K in which the volume of the gas is doubled. BC is an isobaric contraction to the original volume in which the temperature is reduced to 300 K . CA is a constant volume process in which the pressure and temperature return to their initial values. The net amount of heat (in Joules) absorbed by the gas in one complete cycle is _____.

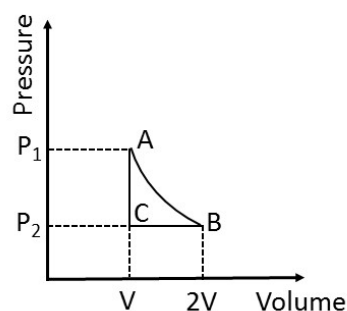

- Q.12 In a region of space, a time dependent magnetic field $B(t) = 0.4 t$ Tesla points vertically upwards. Consider a horizontal, circular loop of radius 2 cm in this region. The magnitude of the electric field (in mV/m) induced in the loop is _____.
- Q.13 A plane electromagnetic wave of frequency 5×10^{14} Hz and amplitude 10^3 V/m, traveling in a homogeneous dielectric medium of dielectric constant 1.69, is incident normally at the interface with a second dielectric medium of dielectric constant 2.25. The ratio of the amplitude of the transmitted wave to that of the incident wave is _____.
- Q.14 For the arrangement given in the following figure, the coherent light sources A, B and C have individual intensities of 2 mW/m^2 , 2 mW/m^2 and 5 mW/m^2 , respectively at point P. The wavelength of each of the sources is 600 nm. The resultant intensity at point P (in mW/m^2) is _____.

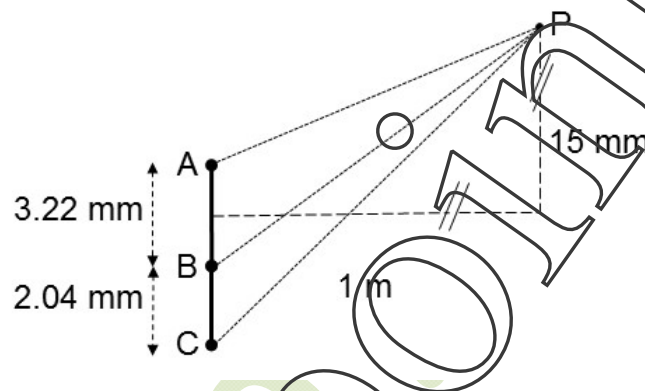

- Q.15 One gram of ice at 0°C is melted and heated to water at 39°C . Assume that the specific heat remains constant over the entire process. The latent heat of fusion of ice is 80 Calories/gm. The entropy change in the process (in Calories per degree) is _____.
- Q.16 A uniform disk of mass m and radius R rolls, without slipping, down a fixed plane inclined at an angle 30° to the horizontal. The linear acceleration of the disk (in m/sec^2) is _____.
- Q.17 A nozzle is in the shape of a truncated cone, as shown in the figure. The area at the wide end is 25 cm^2 and the narrow end has an area of 1 cm^2 . Water enters the wider end at a rate of 500 gm/sec . The height of the nozzle is 50 cm and it is kept vertical with the wider end at the bottom. The magnitude of the pressure difference in kPa ($1 \text{ kPa} = 10^3 \text{ N/m}^2$) between the two ends of the nozzle is _____.

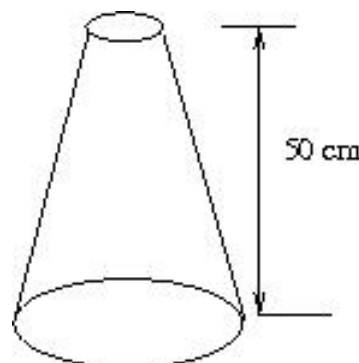

- Q.18 A block of mass 2 kg is at rest on a horizontal table. The coefficient of friction between the block and the table is 0.1. A horizontal force 3 N is applied to the block. The speed of the block (in m/s) after it has moved a distance 10 m is _____.
- Q.19 A homogeneous semi-circular plate of radius $R = 3$ m is shown in the figure. The distance of the center of mass of the plate (in meter) from the point O is _____.

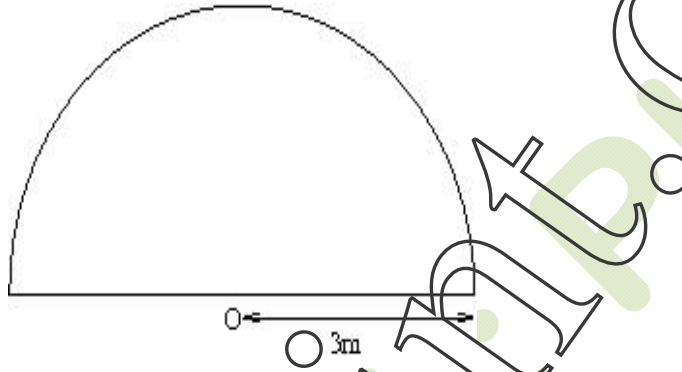

- Q.20 Consider a $20\mu\text{m}$ diameter p-n junction fabricated in silicon. The donor density is 10^{16} per cm^3 . The charge developed on the n-side is 1.6×10^{-14} C. Then the width (in μm) of the depletion region on the n-side of the p-n junction is _____.

END OF THE QUESTION PAPER